

Front membrane pressure sensor FPS-01CA

for pressure control on engines

Front membrane pressure sensor for continuous measurement of cylinder pressure on two- and four stroke engines. (24h per day / 365 days per year)

Characteristics

- Sensor designed for diesel-and gas engines
- Digital electronic with event storing
- Very good thermodynamic performance
- Marine classification in preparation

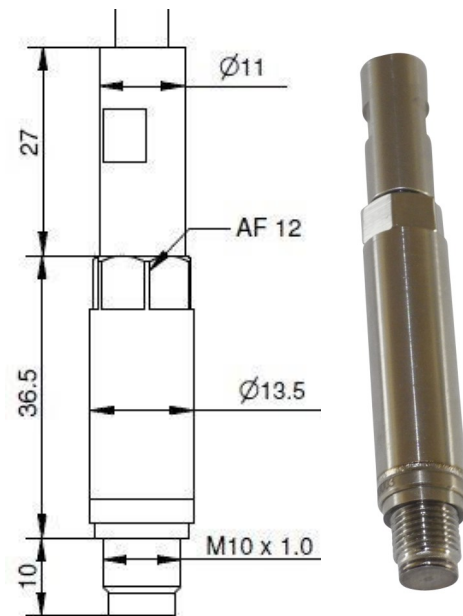

Application:

Permanent installation for engine control.

Technical Data

Measuring range pressure	0...300 bar
Over pressure static	400 bar
Frequency range	10 kHz
Thermal shock 1500 RPM pmi=9bar	< +/- 0,5 bar
Accuracy	≤1% Full scale
Temperature range of SCU	-40 °C ... + 75 °C
Supply voltage	18...32 VDC, on request 5VDC
SCU current consumption	≤50 mA (continuous operation); 250 mA (switch-on peak)
Output signal range	4...20 mA, on request 0,5...4,5 V
Electrical connector	MIL-C-26482
Thread	M10 x 1
Dimension sensor	46,5 mm , Ø 13,5 mm
Dimension electronic	138 mm x 18 mm
Tightening torque	15 Nm
Weight incl. electronic	252 g

General specifications

Degree of protection	IP 67 (EN 60529)
CE approval	2004/1008/EG EN 61000-6-2 EN 61000-6-4 EN 61326-1

The robust type FPS-01CA sensor for continuous measurement of cylinder pressures on two- and four stroke engines offers outstanding longevity and constant sensitivity.

Cylinder pressure measurements can be made with high precision because of its very good thermodynamic characteristics.

Mounting

The sensor should be installed close to the combustion chamber, the length of the pressure bore between sensor and combustion chamber depends mainly on engine speed.

Generally there are two possibilities for the installation position of cylinder pressure sensors:

Head mounted or set-back mounted.

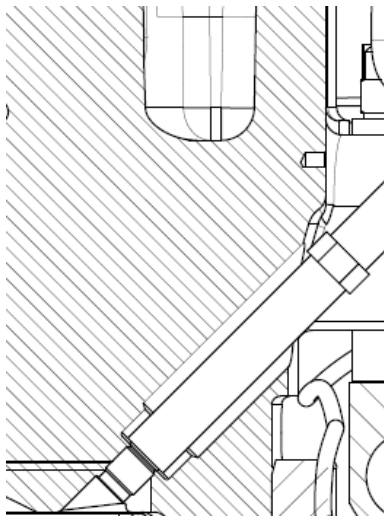

Head mounted installation near to combustion chamber

Connector

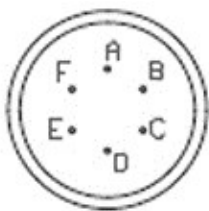

A = Power supply 18 - 32 V

B = Pressure signal output 4...20mA

D = Signal zero point / Power GND

C = Programming pin, only used for calibration

E, F not connected



The closed face makes the sensor immune to sooting

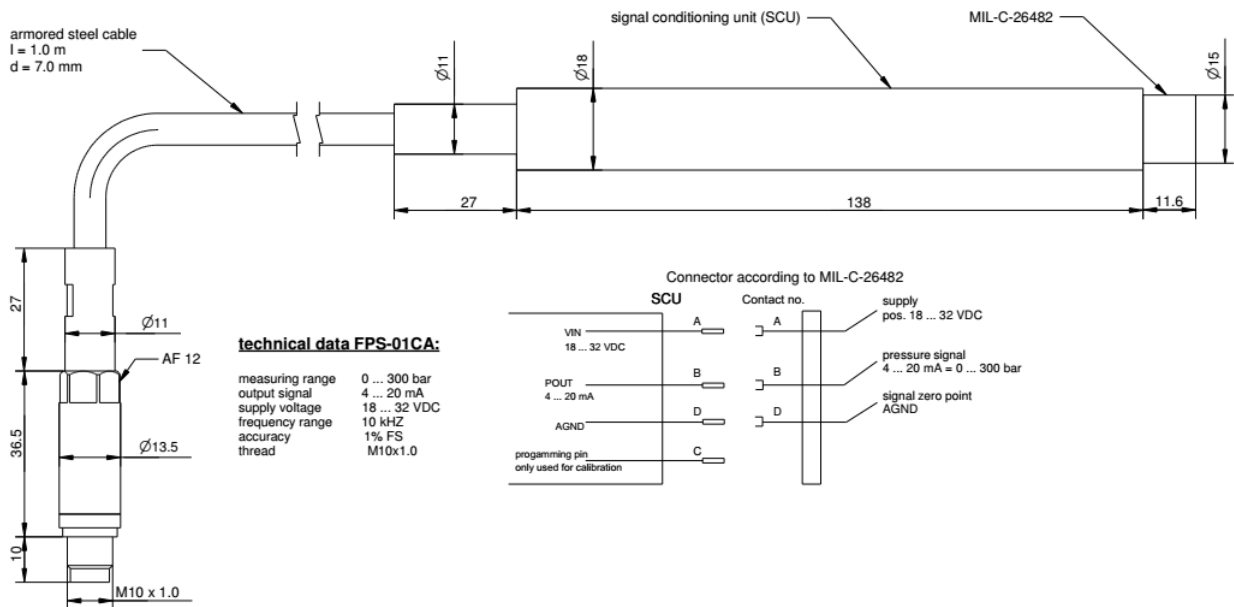

Product No.	Pressure range	Sensor length	Cable length	Static over-pressure
IW-	0 - 300 bar	52 mm	1,0 m	400 bar

Optional Accessories

- Protection cover

Product No.

IW-6211